

EL005 ENVIROMON[®] INDUSTRIAL DATA LOGGING SYSTEM

FOR MONITORING PHARMACEUTICAL STORES AND COLD ROOMS

Blood Banks
Centralized remote monitoring

- Hospital fridges and freezers
- Drugs factories
- Temperature and humidity



Wide use in the cold rooms, blood banks and Pharmaceutical industry



EnviroMon systems are designed specifically for monitoring large areas that require multiple point monitoring and logging of temperature and humidity 24/7. The system is very flexible and easy to maintain, it consists of **EL005** industrial data logger, **EL026** Temperature & Humidity Converters and **EL030** Temperature and humidity probe, all are connects through two pair of CAT 5 Network cable

For temperature only **EL001** precision temperature sensor with **EL001** three channel converter.

Or **SE029** thermocouple and **EI041** four channel thermocouple converter for deep freezer below -40

Functions and instructions

- ❖ The system has its own wired network and own power over the NET, with internal backup battery to keep the system running for at least 3 - 7 days in case of power cut.
- ❖ **EL001** converter with **EL015** temperature sensor or **EL041** with **SE029** thermocouple will be installed on the zones required monitoring, then two pairs CAT 5 cable Daisy Chain all the converter with the **EL005** Data logger, the data logger connects to PC, either direct via RS232, or USB, wireless through modem or router, or via Ethernet.
- ❖ Then the SiteLog software, will show live and records all the sensor value 24/7.



EL001

Three channel
Temperature Converter

EL015

Temperature RTD
Probe
Range -40°C to
70°C



EL005

Industrial
Data logger

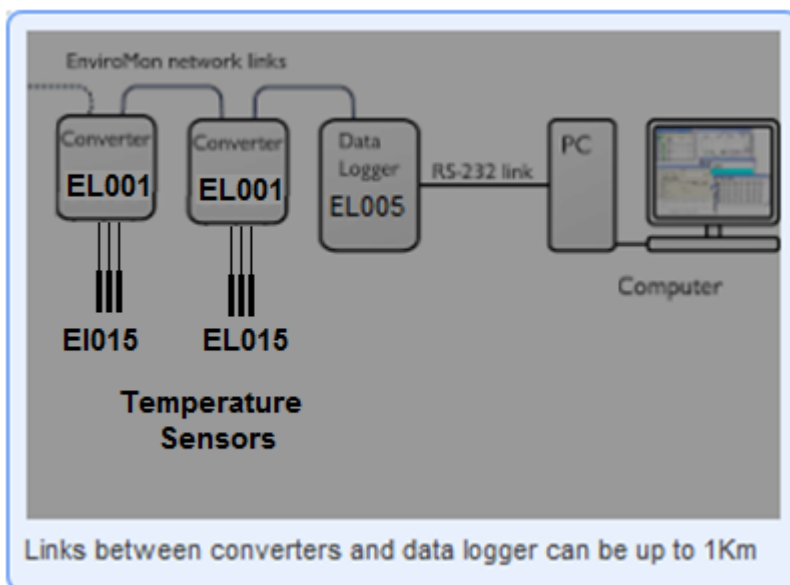

EL041

Four channel
Thermocouple
Converter



SE029

Thermocouple sensor
Range -100°C to 250°C

EnviroMon Connection diagram

EL005 DATA LOGGER MODULE, THE HEART OF THE SYSTEM

EnviroMon Data Logger Specifications	
Logger	EL005
Sampling rate	1 to 240 minutes per sample
Max number of readings	250,000 when disconnected from PC, unlimited when connected to PC (the limit would be only the hard disk memory)
Max number of converters	15
Max number of sensors	40
Communication support	Internet, LAN, WAN, GPRS,3G& 4G
Standard sensors	All Gases, Temperature all ranges , Humidity, differential pressure, power , current voltage, water leak, fire, motion, flow, dust, vibration, Emissions
Optional sensor	You can add any sensor with 4-20mA or 0 to 10VDC output
Power	100 to 240AC or 12 V DC 1A
Battery backup	Internal rechargeable NiMH cells
System Accuracy & resolution	Depends on each module and sensor (see modules below)

EL001 TEMPERATURE CONVERTER AND EL015 PROBE SPECIFICATION

EnviroMon EL005 can measure temperature using the EL001 three channel temperature sensor. Each EL015 is calibrated for high-accuracy measurements. The probe have 5 meter wire to calibration easy.

Sensor	Range	Accuracy	Resolution
EL015 Temperature Sensor	-40 to 70 °C	All range ± 0.3 °C	0.01 °C

BOTTOM OF FORM SITELOG SOFTWARE FEATURE

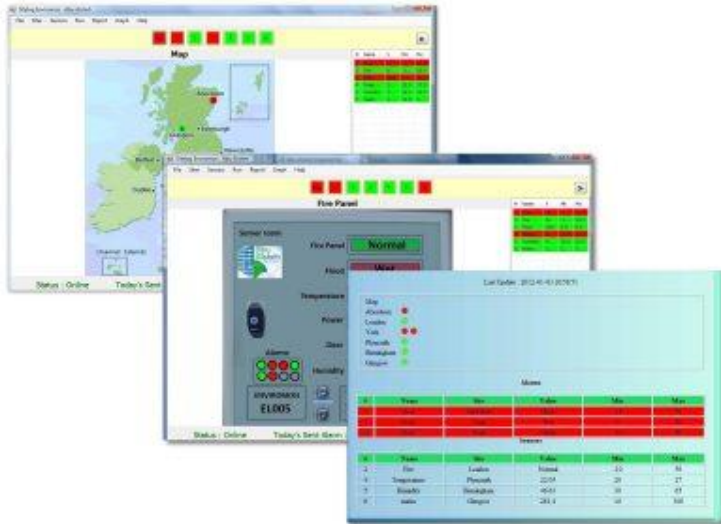

1. Send SMS via the internet to an unlimited number of mobile phones without Modem.
2. Send emails to an unlimited number of email addresses.
3. Monitor Simultaneously unlimited remote EL005 data loggers at different sites worldwide.
4. Drag and drop the sensors reading at any site floor plan, control the colour and size of the reading.
5. Run a batch file or any executable file for each sensor alarm.
6. Select the date and time for data to be saved or printed.
7. Schedule report to store or send to unlimited numbers of e-mails
8. Controls air-condition for power saving
9. Very easy to use
10. Web page remote monitoring.
11. Smart phone monitoring
12. Monitoring IP cameras.
13. Send SMS when system offline
14. Send SMS when LAN/WAN internet Network is not available
15. Site map — drag and drop a complete site on to a map.

ENVIROMON SYSTEM IS DESIGNED AND MANUFACTURED IN UK BY ENVIROMON® LTD.

System Advantages

- 1- Hard wired no interference from external source or data conflicts.
- 2- Powering the Converters and sensor are from the Network, no battery required.
- 3- Data Logger Have Backup battery in case of power cut.
- 4- It's a very Safe system. It's Made in the UK and meets all approvals of the European safety standards.
- 5- Emergency shut down in case of fire, electronics meet UL fire regulation.
- 6- You can add other type of sensor for future system expansion.
- 7- Allows Humidity calibration, when the Humidity deviate with time.
- 8- The system is industrial which been used worldwide for over 20 years without problems.
- 9- Extremely accurate temperature measurement, can be as accurate as 0.1°C, Humidity 0.5%.
- 10- The system has been used in Jordan since year 2000 at many Governmental and private sites.
- 11- Local distributor with Telephone, email support and maintenance for more than 18 years.

EL041 Thermocouple Converter Specifications	
Number of Channels	4
Thermocouples Supported	B, E, J, K, N, R, S, T or mV
Voltage Input Range	±60 mV
Resolution	15 bits + sign
Accuracy	Thermocouples: ±(0.5 °C + 0.3% of type K reading) Millivolts: ±0.3%
Conversion Time	1 second
Overload Protection	±10 V
Input Connector	Mini-thermocouple plugs
PC Connector	via EnviroMon network
Operating Temperature	0 to 70 °C (20 to 30 °C for quoted accuracy)
Operating Humidity	25 to 75%RH

EnviroMon Ltd, Ditchling common, S M Tidy industrial estate, BN6 8SG, United Kingdom
 E-mail: Sales@EnviroMon.eu www.EnviroMon.eu Tel: 004412731811